

DA-820-Ethernet Series Expansion Modules

Expansion modules with 2-port Giga SFP LAN, 2-port 100 Mbps SPF LAN, and 2-Port PRP/HSR Giga LAN



Features and Benefits

- 2-port Giga LAN PRP/HSR module
- 2-port 100 Mbps SFP fiber module (SFP module excluded)
- 2-port 1000 Mbps fiber card, SFP slot x 2 (SFP module excluded)

Introduction

The DA-820-Ethernet expansion modules, with choice of Fiber LAN ports and PRP/HSR communication redundancy ports, provide superior flexibility for industrial applications. The 2/4-port Fiber LAN modules are suitable for industrial communication applications with Ethernet-based devices. The DA-PHR-PTP expansion module is compliant with IEC 62439-3 Clause 4 (PRP) and IEC 62439-3 Clause 5 (HSR) to ensure the highest system availability and data integrity for mission-critical applications that require redundancy and zero-time recovery. With dual Gigabit Ethernet port design, the DA-PRP-HSR module provides high performance for redundant network systems. In addition, the DA-PRP-HSR features built-in native PRP/HSR management middleware with MMS server that allows SCADA systems to collect IEC62439-3 registers from multiple devices for easy network diagnosis, troubleshooting, device management, and monitoring. All modules are designed to offer the greatest flexibility for setting up applications and performing industrial tasks.

Appearance

DA-PRP-HSR

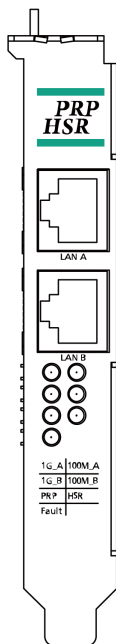

DE-GX02-SFP-T

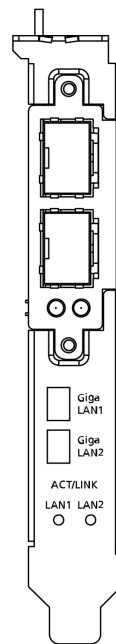

DE-FX02-SFP-T

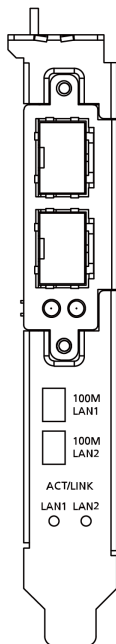

Specifications

Ethernet Interface

10/100/1000BaseT(X) Ports (RJ45 connector)	DA-PRP-HSR: 2
100 Mbps fiber (SFP connector)	DE-GX02-SFP-T: 2
1000 Mbps fiber (SFP connector)	DE-FX02-SFP-T: 2
Magnetic Isolation Protection	1.5 kV (built-in)

Physical Characteristics

Dimensions (without ears)	DA-PRP-HSR: 167 x 111 mm (6.6 x 4.38 in) DE-FX02-SFP-T, DE-GX02-SFP-T: 183 x 106.65 mm (7.2 x 4.19 in)
Weight	DE-FX02-SFP-T: 218 g (0.48 lb) DE-GX02-SFP-T: 220 g (0.49 lb) DA-PRP-HSR: 212 g (0.47 lb)

Environmental Limits

Operating Temperature	-40 to 75°C (-40 to 167°F)
Storage Temperature (package included)	-40 to 85°C (-40 to 185°F)

Declaration

Green Product	RoHS, CRoHS, WEEE
---------------	-------------------

MTBF

Time	DE-FX02-SFP-T: 1,403,659 hrs DE-GX02-SFP-T: 1,403,659 hrs DA-PRP-HSR: 1,707,210 hrs
Standards	Telcordia (Bellcore), GB

Warranty

Warranty Period	3 years
Details	See www.moxa.com/warranty

Package Contents

Device	1 x DA-820-Ethernet Series expansion module
Documentation	1 x warranty card

Dimensions

DA-PRP-HSR

Unit: mm (inch)

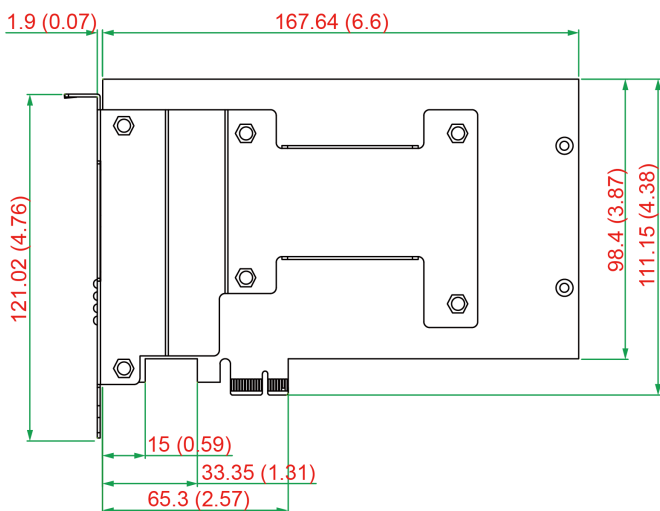

DE-GX02-SFP-T

Unit: mm (inch)

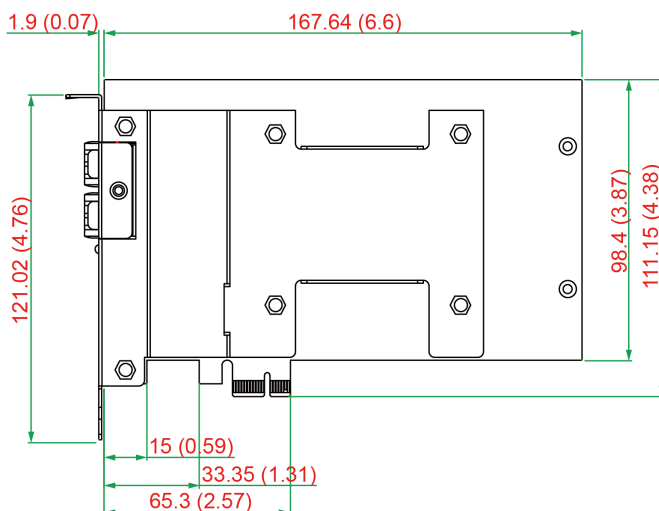

DE-FX02-SFP-T

Unit: mm (inch)

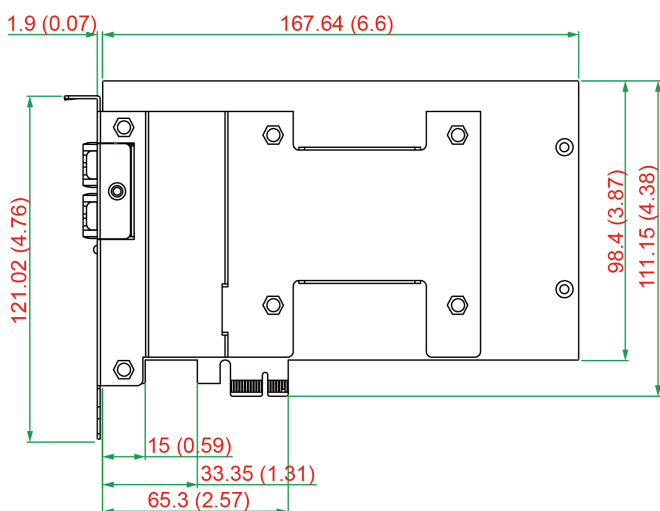

Ordering Information

Model Name	Port	100 Mbps	100/1000 Mbps	1000 Mbps	RJ45	SFP	PRP/HSR
DE-FX02-SFP-T	2	✓	-	-	-	✓	-
DE-GX02-SFP-T	2	-	-	✓	-	✓	-
DA-PRP-HSR	2	-	✓	-	✓	-	✓

© Moxa Inc. All rights reserved. Updated Nov 12, 2018.

This document and any portion thereof may not be reproduced or used in any manner whatsoever without the express written permission of Moxa Inc. Product specifications subject to change without notice. Visit our website for the most up-to-date product information.